



# Ortho CAPE

**FOOT SURGERY**

Pour toute question concernant nos produits,  
contactez-nous sur [info@ortho-cape.com](mailto:info@ortho-cape.com)

# NOS FRAISES PERCUTANÉES

OrthoCAPE



- Fraises en acier X90CrMoV18
- Chirurgie percutanée
- Conditionnement unitaire stérile
- Fraises standards Ø 2.32 Lg 70 mm

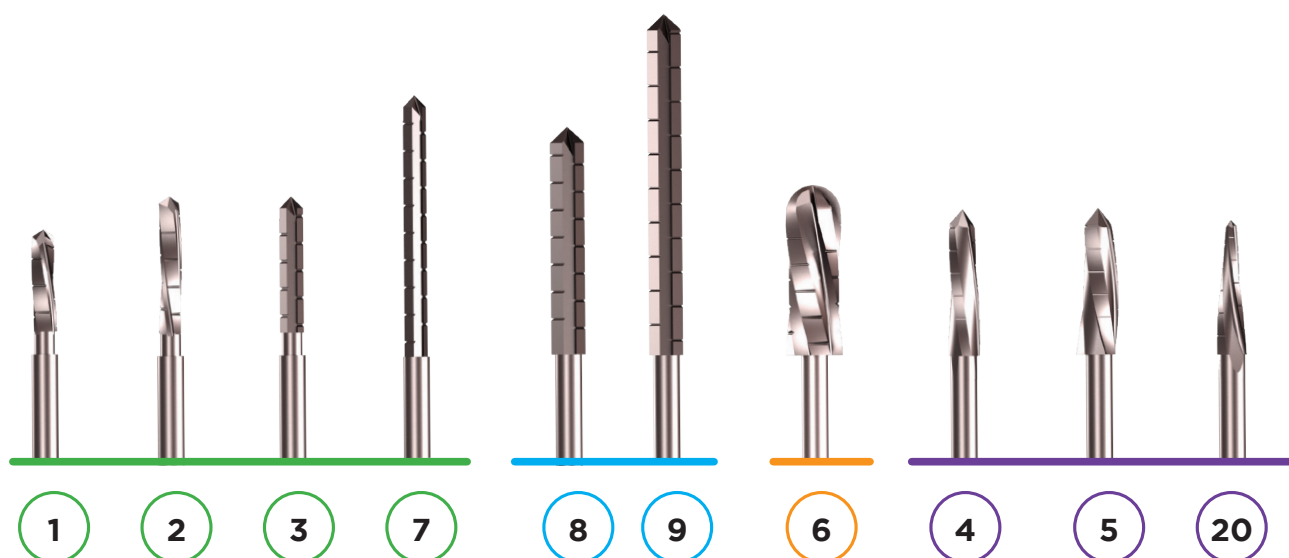

	N°	RÉF.	Ø	LG DE COUPE	LG FRAISE
SHANNON COURTE	①	38.37.01	2 MM	8 MM	70 MM
SHANNON LONGUE	②	38.37.02	2 MM	12 MM	70 MM
SHANNON ISHAM	③	38.37.03	2 MM	12 MM	70 MM
WEDGE Ø3,1	④	38.37.04	3,1 MM	13 MM	70 MM
WEDGE Ø4,1	⑤	38.37.05	4,1 MM	13 MM	70 MM
BROPHY	⑥	38.37.06	5 MM	15 MM	70 MM
SHANNON XL	⑦	38.37.07	2 MM	22 MM	70 MM
SHANNON XXL	⑧	38.37.08	3 MM	20 MM	70 MM
SHANNON XXL LG 30	⑨	38.37.09	3 MM	30 MM	100 MM
CONIQUE	⑳	38.37.20	3,1 MM	13 MM	70 MM

**Sur commandes spéciales :**  
 - fraises longueurs totales 50 mm et 65 mm  
 - embouts Stryker

# NOS INSTRUMENTS PERCUTANÉS

OrthoCAPE

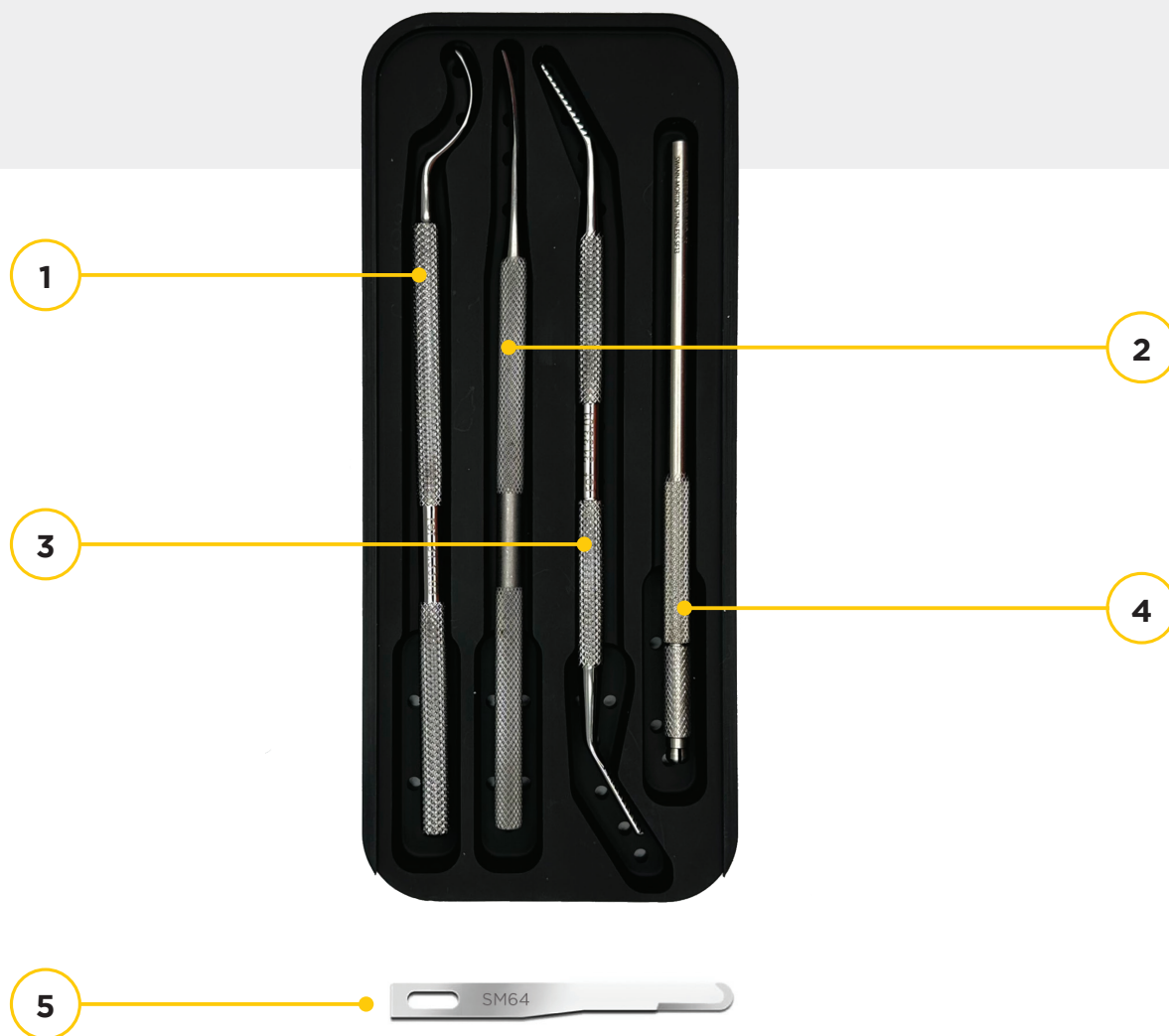

## ANCILLAIRE

N°	PRODUIT	RÉF.
1	Elévateur	31.33.02
2	Levier à os	31.33.03
3	Râpe à os	31.33.01
4	Porte lame Beaver 15.5cm	6061
5	Lames de bistouri Beaver (boîte de 25) SM64	5904
6	Boîte de rangement	14.10.99

# NOTRE GAMME DE VIS

OrthoCAPE

SCREWDRIVER

Ø2.0 Ø2.5

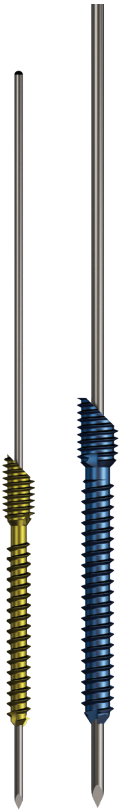

Ø 3.0 Ø 4.0

MI SCREW

Ø2.5 Ø4.0



Ø 4.6 Ø 7.0

EAGLE

Ø2.5 Ø4.0

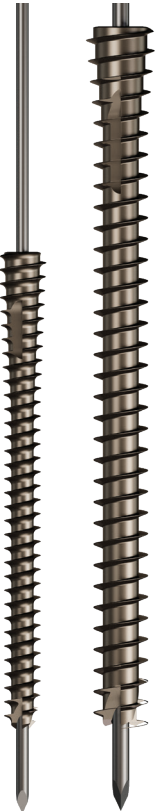

Ø 4.6 Ø 7.0

ARTHROSTAB

SCREWDRIVER

Ø2.0



Ø 2.0

MISS

Ø2.0



Ø 2.0

SBS

Torx T7



Ø 2.5

MY SCREW

Ø2.0



Ø 2.6

Ø2.0



Ø 3.0

PPDA

# NOS RÉFÉRENCES

OrthoCAPE

VIS				
NOM.	Ø	LONG.		RÉF.
MI SCREW Ø3	3.0	18 à 60 MM		38.92.xx
MI SCREW Ø4	4.0	32 à 60 MM		38.23.xx
EAGLE Ø4.6	4.6	20 à 60 MM		38.98.xx
EAGLE Ø7	7.0	30 à 90 MM	FILETAGE 16	38.99.xxA
EAGLE Ø7	7.0	55 à 90 MM	FILETAGE 22	38.99.xxB
EAGLE Ø7	7.0	70 à 90 MM	FILETAGE 28	38.99.xxC
ARTHROSTAB Ø4.6	4.6	20 à 60 MM		38.21.xx
ARTHROSTAB Ø7	7.0	30 à 90 MM		38.22.xx
MISS	2.0	13 à 22 MM		38.52.xx
SBS	2.0	09 à 24 MM		14.52.xx
MY SCREW	2.5	12 à 34 MM		38.88.xx
PPDA Ø2.6	2.6	12 à 34 MM		38.49.xx
PPDA Ø3	3.0	12 à 34 MM		38.65.xx
BROCHE	0.8	70 MM		14.63.41
BROCHE	1.0	70 MM		14.63.01
BROCHE	1.0	150 MM	1 PTE TROCART	14.63.48
BROCHE	1.50	150 MM	1 PTE TROCART	14.63.44
BROCHE	2.2	200 MM	1 PTE TROCART	14.63.10

# MI SCREW

Ø 3.0 MM Ø 4.0 MM

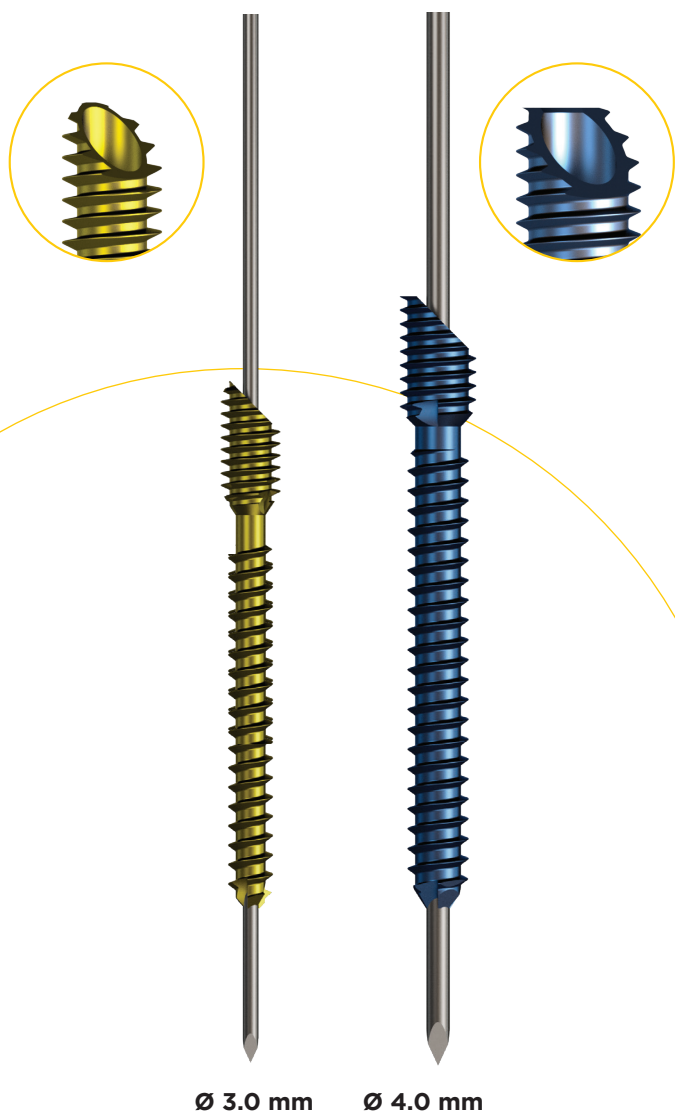

- Vis titane ISO 5832-3
- Autoforeuse et auto-taraudeuse
- Avant-pied
- Conditionnement stérile
- Broche Ø 1.0 pour vis Ø 3.0 mm  
Broche Ø 1.5 pour vis Ø 4.0 mm

	Ø 3.0	Ø 4.0
LONG.	RÉF.	RÉF.
18	38.92.18	
20	38.92.20	
22	38.92.22	
24	38.92.24	
26	38.92.26	
28	38.92.28	
30	38.92.30	
32	38.92.32	38.23.32
34	38.92.34	38.23.34
36	38.92.36	38.23.36
38	38.92.38	38.23.38
40	38.92.40	38.23.40
42	38.92.42	38.23.42
44	38.92.44	38.23.44
46	38.92.46	38.23.46
48	38.92.48	38.23.48
50	38.92.50	38.23.50
52	38.92.52	38.23.52
54	38.92.54	38.23.54
56	38.92.56	38.23.56
58	38.92.58	38.23.58
60	38.92.60	38.23.60

## ANCILLAIRE

N°	PRODUIT	RÉF.
1	Forêt tête pour vis Ø 4.0	14.37.21
2	Tournevis (lame) canulé Mi Screw Ø 4.0	14.30.10
3	Forêt pour vis Ø 4.0	14.37.33
4	Manche de tournevis AO universel	14.32.03
5	Broches Ø 1.50 Lg 150 mm 1 pointe trocart	14.63.44
6	Tournevis (lame) canulé pour vis Ø 3.0	14.30.23
7	Forêt pour vis Ø 3.0	14.37.24
8	Mesureur sur broche 150 mm	14.33.33
9	Forêt tête pour vis Ø 3.0	14.37.20
10	Broches Ø 1.0 Lg 150 mm 1 pointe trocart	14.63.48
11	Boîte de rangement	14.10.01

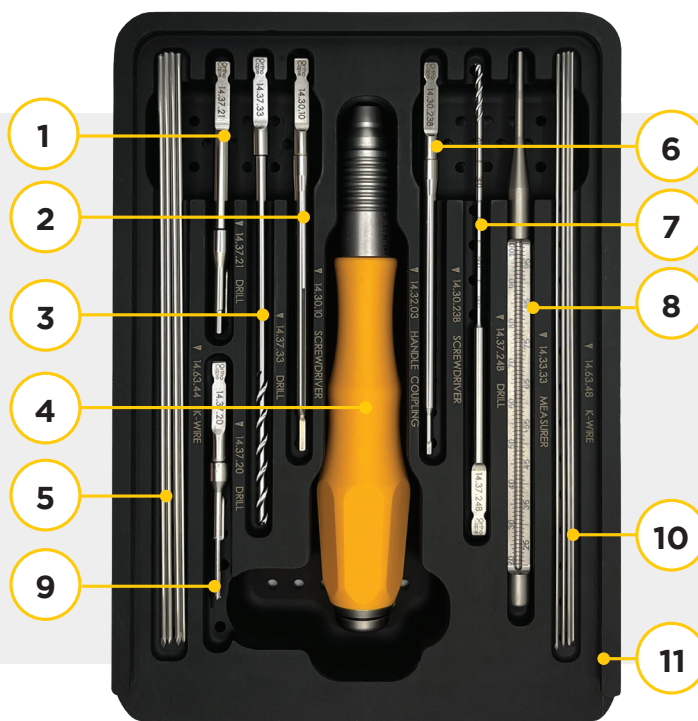

# EAGLE

Ø 4.6 MM Ø 7.0 MM

- Vis titane ISO 5832-3
- Medio et arrière-pied
- Conditionnement stérile
- Broche Ø 1.5 pour vis Ø 4.6 mm  
Broche Ø 2.2 pour vis Ø 7.0 mm

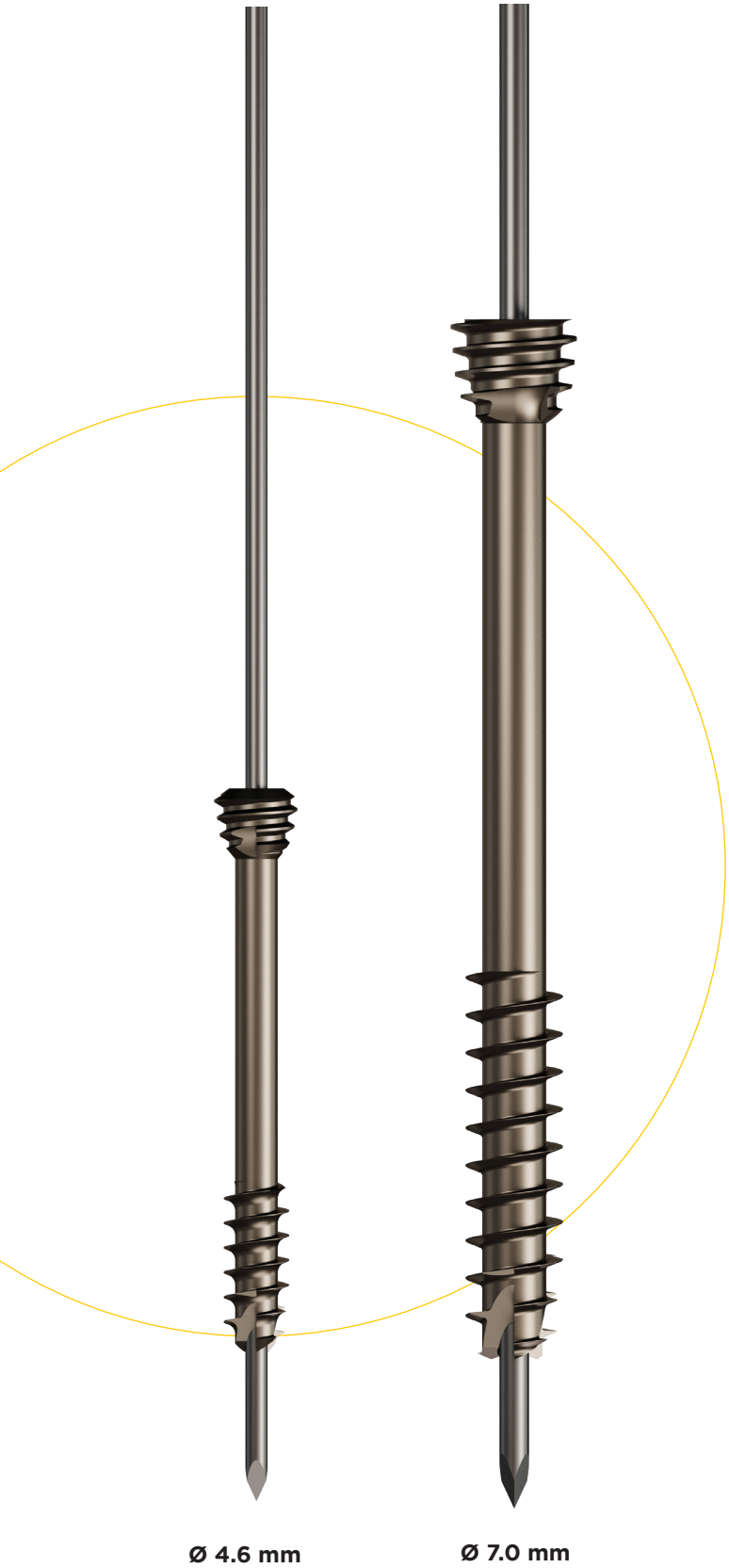

Ø 4.6 mm

Ø 7.0 mm

Ø 4.6 mm	
LONG.	RÉF.
20	38.98.20
22	38.98.22
24	38.98.24
26	38.98.26
28	38.98.28
30	38.98.30
32	38.98.32
34	38.98.34
36	38.98.36
38	38.98.38
40	38.98.40
42	38.98.42
44	38.98.44
46	38.98.46
48	38.98.48
50	38.98.50
52	38.98.52
54	38.98.54
56	38.98.56
58	38.98.58
60	38.98.60

Ø 7.0 mm					
LONG.	RÉF.	LONG.	RÉF.	LONG.	RÉF.
FILETAGE 16 MM		FILETAGE 22 MM		FILETAGE 28 MM	
30	38.99.30A				
35	38.99.35A				
40	38.99.40A				
45	38.99.45A				
50	38.99.50A				
55	38.99.55A	55	38.99.55B		
60	38.99.60A	60	38.99.60B		
65	38.99.65A	65	38.99.65B		
70	38.99.70A	70	38.99.70B	70	38.99.70C
75	38.99.75A	75	38.99.75B	75	38.99.75C
80	38.99.80A	80	38.99.80B	80	38.99.80C
85	38.99.85A	85	38.99.85B	85	38.99.85C
90	38.99.90A	90	38.99.90B	90	38.99.90C



# EAGLE - ARTHROSTAB

Ø 4.6 MM Ø 7.0 MM

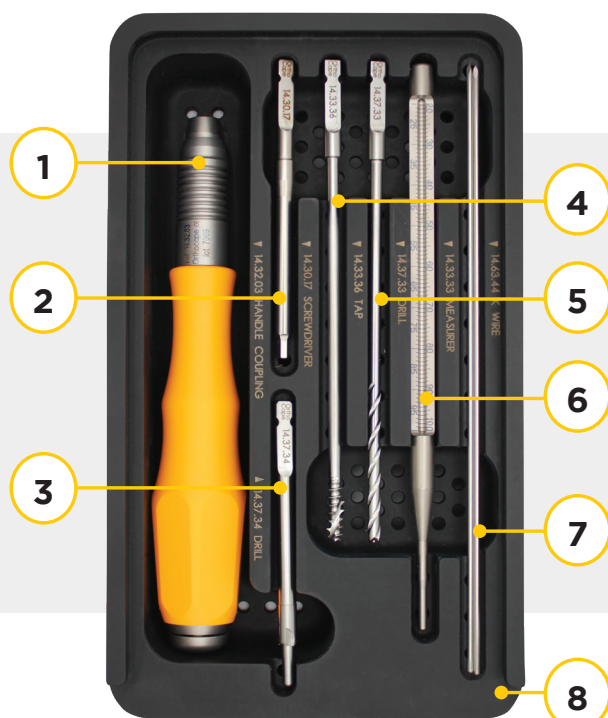

## Ø 4.6 MM

### ANCILLAIRE

	PRODUIT	RÉF.
1	Manche de tournevis AO universel	14.32.03
2	Tournevis (lame) pour vis Ø 4.6	14.30.17
3	Forêt tête pour vis Ø 4.6	14.37.34
4	Taraud Eagle Arthrostab Ø 4.6	14.33.36
5	Forêt pour vis Ø 4.6	14.37.33
6	Mesureur sur broche 150 mm	14.33.33
7	Broches Ø 1.5 Lg 150 mm 1 pointe trocart	14.63.44
8	Boîte de rangement	14.10.96

Les vis s'utilisent avec 1 broche Ø 1,5 lg 150 mm  
1 pointe trocart

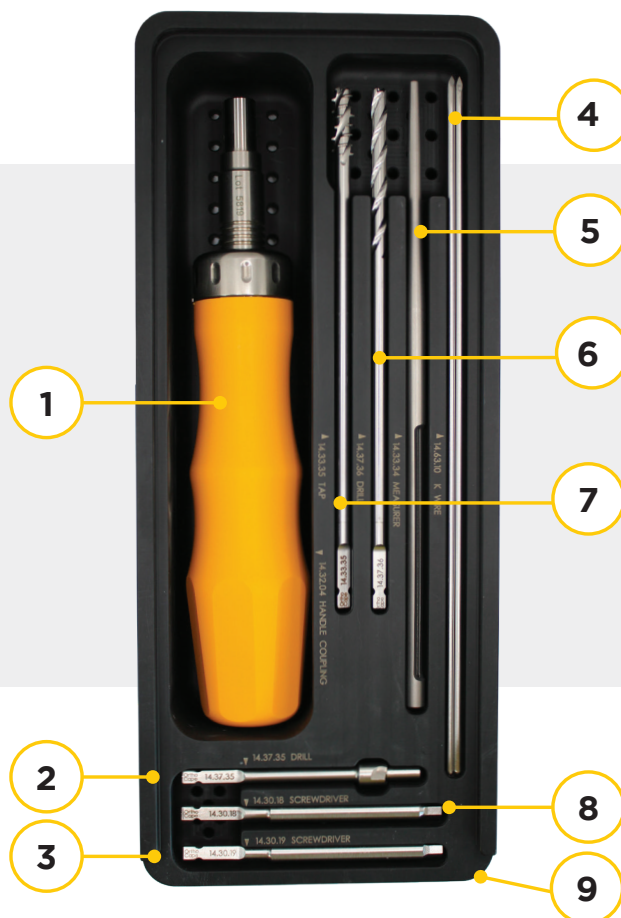

## Ø 7.0 MM

### ANCILLAIRE

	PRODUIT	RÉF.
1	Manche de tournevis Eagle Arthrostab Ø 7.0	14.32.04
2	Forêt tête pour vis Ø 7.0	14.37.35
3	Tournevis (lame) percé pour vis Ø 7.0	14.30.18
4	Broches Ø 2.2 Lg 200 mm 1 pointe trocart	14.63.10
5	Mesureur sur broche 200 mm	14.33.34
6	Forêt canulé pour vis Ø 7.0	14.37.36
7	Taraud Eagle Arthrostab Ø 7.0	14.33.35
8	Tournevis (lame) pour vis Ø 7.0	14.30.19
9	Boîte de rangement	14.10.97

Les vis s'utilisent avec 1 broche Ø 2,2 lg 200 mm  
1 pointe trocart



# ARTHROSTAB

Ø 4.6 MM Ø 7.0 MM

- Vis titane ISO 5832-3
- Medio et arrière-pied
- Conditionnement stérile
- Broche Ø 1.5 pour vis Ø 4.6 mm  
Broche Ø 2.2 pour vis Ø 7.0 mm

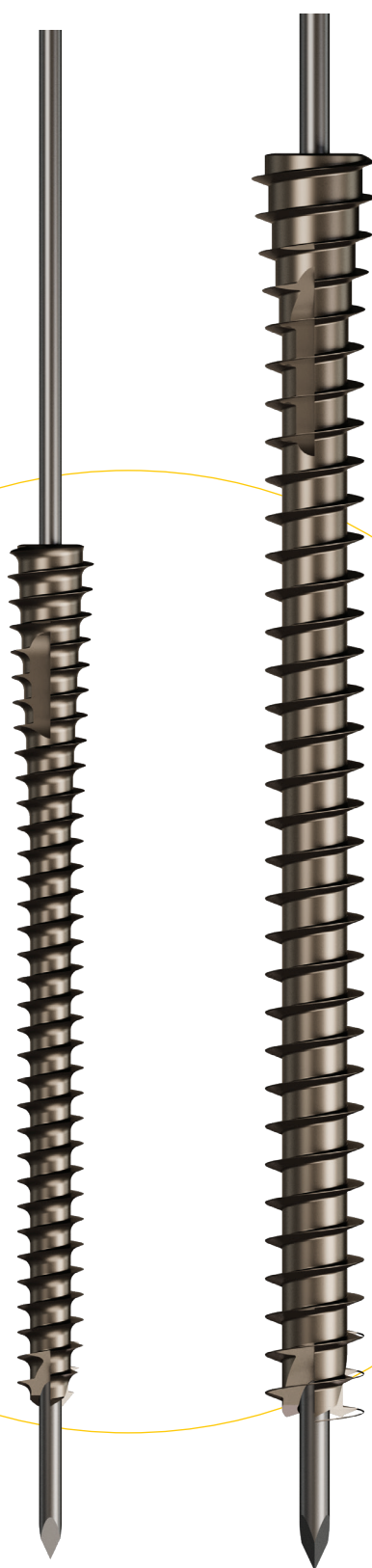

Ø 4.6 mm

Ø 7.0 mm

## Ø 4.6 mm

LONG.	RÉF.
20	38.21.20
22	38.21.22
24	38.21.24
26	38.21.26
28	38.21.28
30	38.21.30
32	38.21.32
34	38.21.34
36	38.21.36
38	38.21.38
40	38.21.40
42	38.21.42
44	38.21.44
46	38.21.46
48	38.21.48
50	38.21.50
52	38.21.52
54	38.21.54
56	38.21.56
58	38.21.58
60	38.21.60

## Ø 7.0 mm

LONG.	RÉF.
30	38.22.30
35	38.22.35
40	38.22.40
45	38.22.45
50	38.22.50
55	38.22.55
60	38.22.60
65	38.22.65
70	38.22.70
75	38.22.75
80	38.22.80
85	38.22.85
90	38.22.90

# EAGLE - ARTHROSTAB

Ø 4.6 MM Ø 7.0 MM

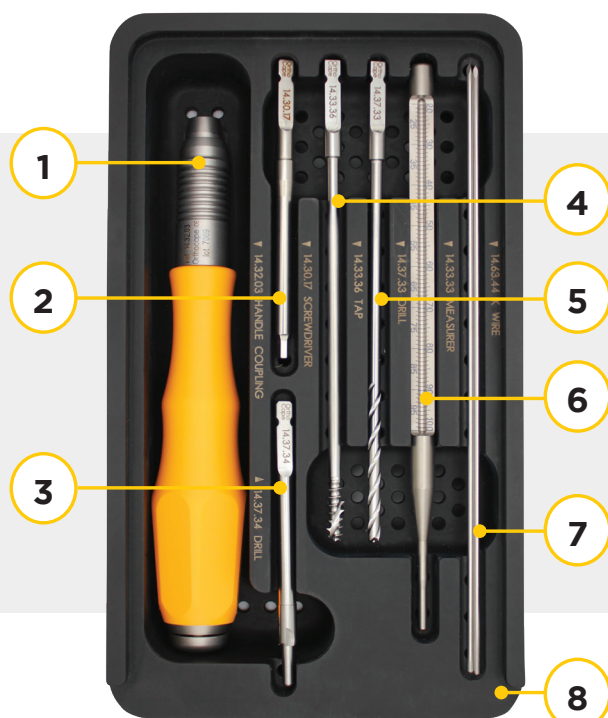

## Ø 4.6 MM

### ANCILLAIRE

	PRODUIT	RÉF.
1	Manche de tournevis AO universel	14.32.03
2	Tournevis (lame) pour vis Ø 4.6	14.30.17
3	Forêt tête pour vis Ø 4.6	14.37.34
4	Taraud Eagle Arthrostab Ø 4.6	14.33.36
5	Forêt pour vis Ø 4.6	14.37.33
6	Mesureur sur broche 150 mm	14.33.33
7	Broches Ø 1.5 Lg 150 mm 1 pointe trocart	14.63.44
8	Boîte de rangement	14.10.96

Les vis s'utilisent avec 1 broche Ø 1,5 lg 150 mm  
1 pointe trocart

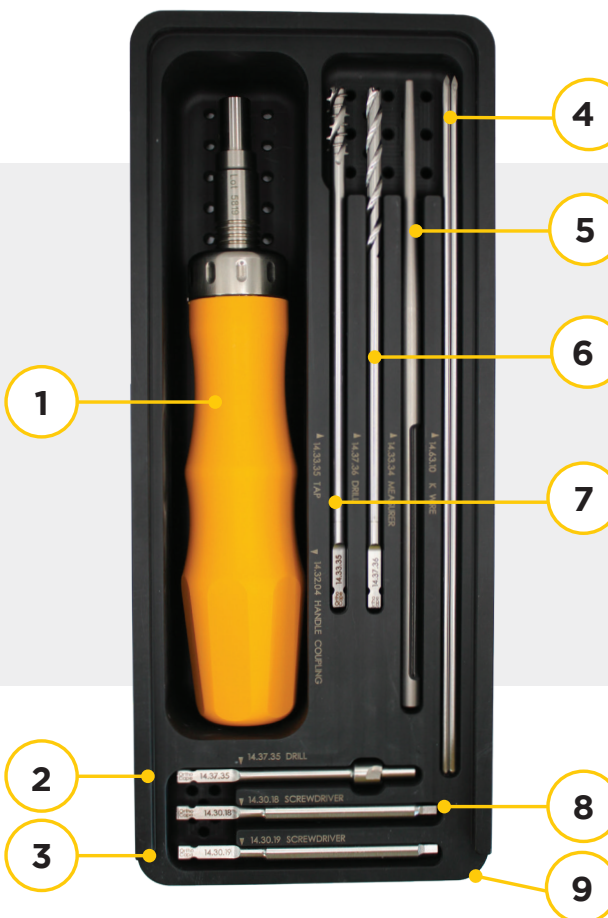

## Ø 7.0 MM

### ANCILLAIRE

	PRODUIT	RÉF.
1	Manche de tournevis Eagle Arthrostab Ø 7.0	14.32.04
2	Forêt tête pour vis Ø 7.0	14.37.35
3	Tournevis (lame) percé pour vis Ø 7.0	14.30.18
4	Broches Ø 2.2 Lg 200 mm 1 pointe trocart	14.63.10
5	Mesureur sur broche 200 mm	14.33.34
6	Forêt canulé pour vis Ø 7.0	14.37.36
7	Taraud Eagle Arthrostab Ø 7.0	14.33.35
8	Tournevis (lame) pour vis Ø 7.0	14.30.19
9	Boîte de rangement	14.10.97

Les vis s'utilisent avec 1 broche Ø 2,2 lg 200 mm  
1 pointe trocart

# MISS

Ø 2.0 MM

- Vis en titane ISO 5832-3
- Sécable, auto perforante et auto taraudeuse
- Avant-pied
- Conditionnement stérile



Ø 2.0 mm

Ø 2.0	
LONG.	RÉF.
13	38.52.13
15	38.52.15
17	38.52.17
19	38.52.19
22	38.52.22

## ANCILLAIRE

N°	PRODUIT	RÉF.
1	Pointe carré pour vis MISS	14.33.25
2	Lame AO pour vis MISS	14.30.12
3	Manche de Tournevis AO	14.32.03
4	Guide de coupe gauche	14.33.39
5	Guide de coupe droit	14.33.39



1

**Pointe carrée pour vis MISS**

14.33.25

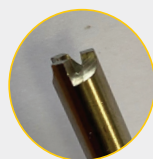

2

**Lame AO pour vis MISS**

14.30.12

3

**Manche de tournevis AO**



4

**Guide de coupe gauche**

14.33.39



5

**Guide de coupe droit**

14.33.39

# SBS

Ø 2.0



Ø 2.0mm

- Vis en titane ISO 5832-3
- Sécable, auto perforante et auto taraudeuse
- Avant-pied
- Conditionnement stérile

Ø 2.0 mm

LONG.	RÉF.
09	14.52.09
11	14.52.11
12	14.52.12
13	14.52.13
14	14.52.14
15	14.52.15
17	14.52.17
19	14.52.19
21	14.52.21
24	14.52.24

## ANCILLAIRE

N°	PRODUIT	RÉF.
1	Lame de tournevis SBS	14.30.02
2	Manche de Tournevis AO	14.32.03

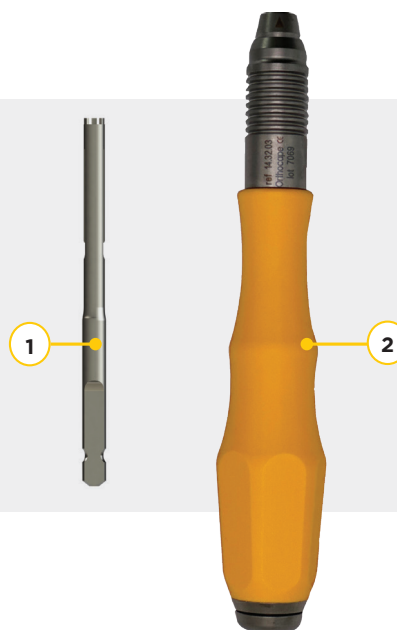

# MY SCREW

Ø 2.5 MM



Ø 2.5 mm

- Vis en titane ISO 5832-3
- Auto taraudeuse, auto foreuse et auto compressive
- Avant-pied
- Conditionnement stérile
- Broche Ø 1.0 pour vis Ø 2.5 mm

Ø 2.5 mm	
LONG.	RÉF.
12	38.88.12
14	38.88.14
16	38.88.16
18	38.88.18
20	38.88.20
22	38.88.22
24	38.88.24
26	38.88.26
28	38.88.28
30	38.88.30
32	38.88.32
34	38.88.34

## ANCILLAIRE

N°	PRODUIT	RÉF.
1	Forêt canulé pour vis My Screw Ø2.5	14.37.25
2	Forêt canulé pour vis My Screw Ø2.5 XL	14.37.27
3	Manche de tournevis AO universel	14.32.03
4	Mesureur sur broche 70 mm	14.33.22
5	Tournevis (lame) Torx 7	14.30.22
6	Tournevis (lame) Torx 7 canulé	14.30.21
7	Broches Ø 1.0 Lg 70 mm	14.63.01
8	Boite de rangement	14.10.88

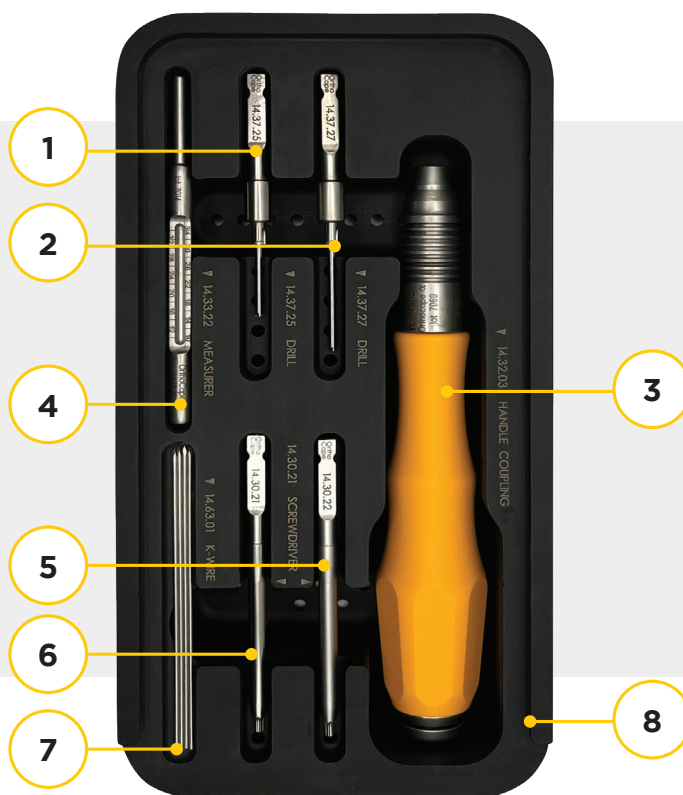

# PPDA

Ø 2.6 MM Ø 3.0 MM

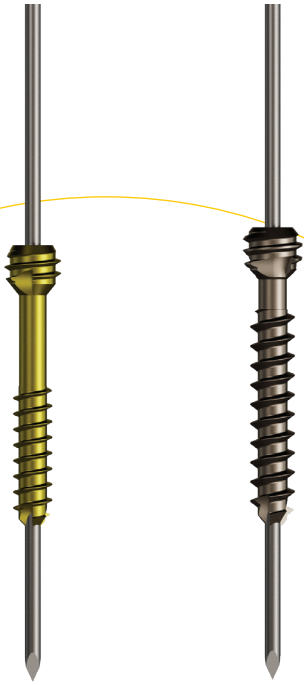

Ø 2.6 mm

Ø 3.0 mm

- Vis en Titane ISO 5832-3
- Auto foreuse, perforée, pas différents, auto compressive
- Avant-pied
- Conditionnement stérile
- Broche Ø1.0 pour vis Ø 2.6 et Ø 3.0mm

Ø 2.6 mm		Ø 3.0 mm	
LONG.	RÉF.	LONG.	RÉF.
12	38.49.12	12	38.65.12
14	38.49.14	14	38.65.14
16	38.49.16	16	38.65.16
18	38.49.18	18	38.65.18
20	38.49.20	20	38.65.20
22	38.49.22	22	38.65.22
24	38.49.24	24	38.65.24
26	38.49.26	26	38.65.26
28	38.49.28	28	38.65.28
30	38.49.30	30	38.65.30
32	38.49.32	32	38.65.32
34	38.49.34	34	38.65.34

## ANCILLAIRE

N°	PRODUIT	RÉF.
1	Forêt canulé pour vis PPDA Ø 2.6 XL	14.37.25
2	Forêt canulé pour vis PPDA Ø 3.0 XL	14.37.26
3	Forêt canulé pour vis PPDA Ø 2.6	14.37.27
4	Tournevis (lame) canulé pour vis Ø2.6 et Ø3	14.30.23
5	Manche de tournevis AO universel	14.32.03
6	Mesureur sur broche 70 mm	14.33.22
7	Broches Ø 1.0 Lg 70 mm	14.63.01
8	Boite de rangement	14.10.88

Disponible en complément d'ancillaire :

- Forêt canulé Ø 3.0 : référence : 14.37.23

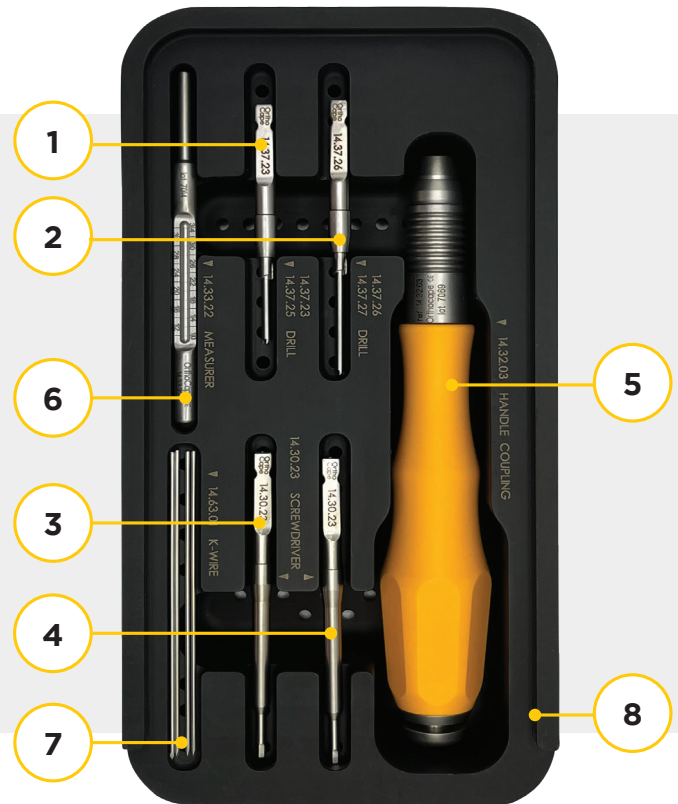



# NOS AGRAFES DE VARISATION

ANGLE 26° OU 90°

- Agrafes en inox 316L ISO 5832-1
- Conditionnement stérile
- Pour ostéotomies AKIN

	ANGLE 26°	ANGLE 90°
Écartement 8 mm	14.55.04	14.55.02
Écartement 10 mm	14.55.03	14.55.01

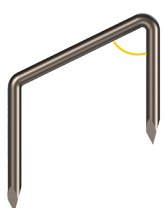

ANGLE 26°

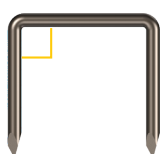

ANGLE 90°

ANCILLAIRE		
N°	PRODUIT	RÉF.
1	Guide de perçage	14.33.55
2	Positionneur 26°	14.33.52
3	Impacteur 26°	14.33.54
4	Positionneur 90°	14.33.51
5	Impacteur 90°	14.33.53
6	Boîte de rangement	14.10.50

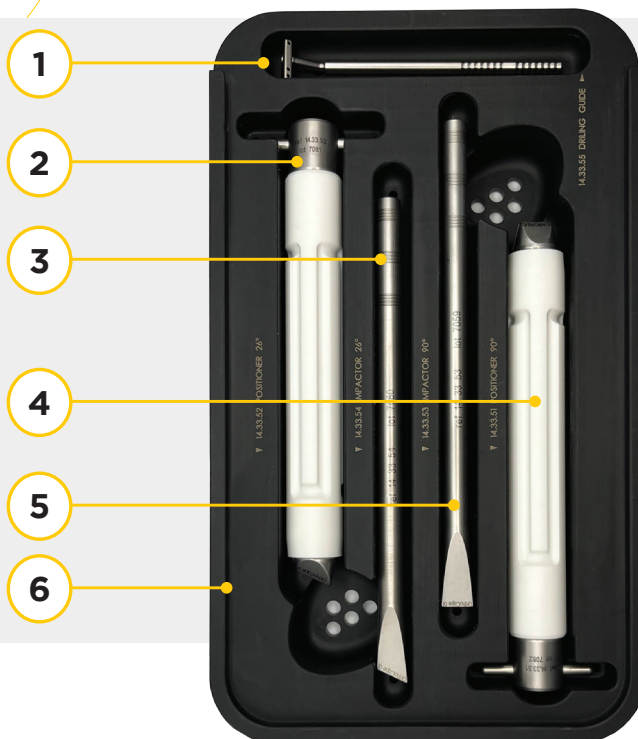

# NOS BROCHES À BILLE

LONGUEUR 150 MM



**BROCHE FILETÉE  
ET EMBOUT ANTI-MIGRATION**

- Inox 316L répondant à la norme ISO 5832-1
- Extrémités triangulaires
- Conditionnement à l'unité stérile broche + embout

## *Longueur 150 mm*

DIAMÈTRE	RÉF.
broche filetée Ø 1.0 mm + embout antimigration	38.63.13/18
broche filetée Ø 1.2 mm + embout antimigration	38.63.14/18
broche filetée Ø 1.5 mm + embout antimigration	38.63.15/19
broche filetée Ø 1.8 mm + embout antimigration	38.63.16/20
broche filetée Ø 2.0 mm + embout antimigration	38.63.17/20



TÉL. +33 5 62 27 02 25



info@ortho-cape.com



172 rue Lépine 82000 Montauban

Télécharger le certificat CE



**[www.ortho-cape.com](http://www.ortho-cape.com)**



IBAN FR76 1027 8022 0000 0210 4320 276 - BIC CMCIFR2A  
N°TVA - FR 61 890810542

SIREt 890 810 542 00021 - APE 3250A