

# MI SCREW

Ø 3.0 MM Ø 4.0 MM

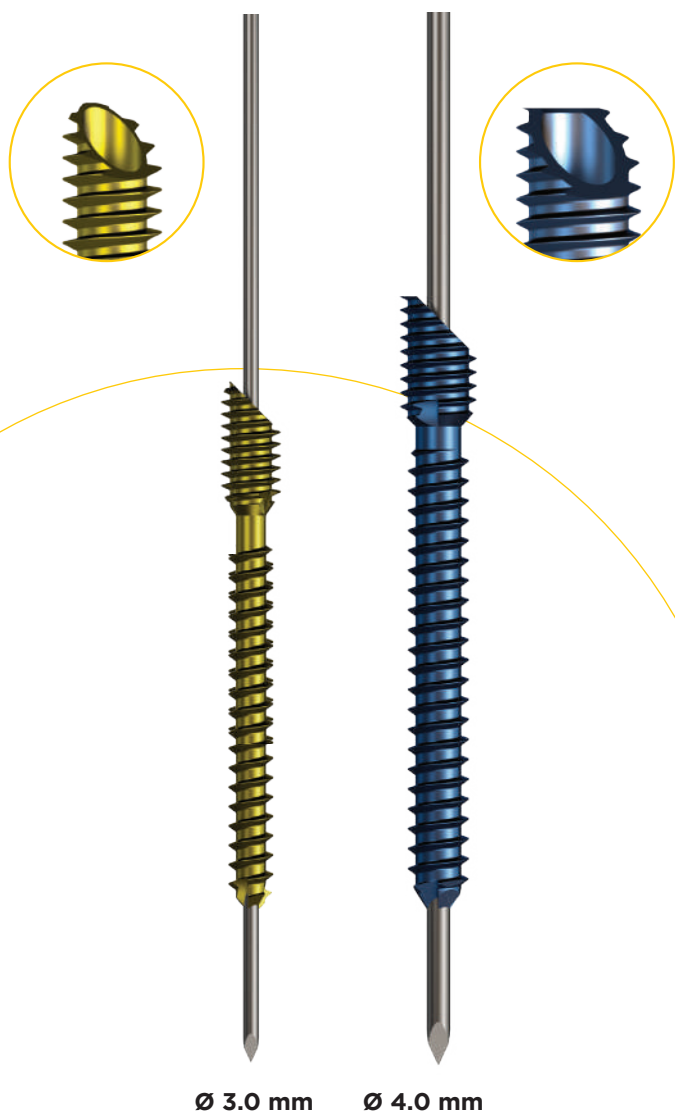

- Vis titane ISO 5832-3
- Autoforeuse et auto-taraudeuse
- Avant-pied
- Conditionnement stérile
- Broche Ø 1.0 pour vis Ø 3.0 mm
- Broche Ø 1.5 pour vis Ø 4.0 mm

|       | Ø 3.0    | Ø 4.0    |
|-------|----------|----------|
| LONG. | RÉF.     | RÉF.     |
| 18    | 38.92.18 |          |
| 20    | 38.92.20 |          |
| 22    | 38.92.22 |          |
| 24    | 38.92.24 |          |
| 26    | 38.92.26 |          |
| 28    | 38.92.28 |          |
| 30    | 38.92.30 |          |
| 32    | 38.92.32 | 38.23.32 |
| 34    | 38.92.34 | 38.23.34 |
| 36    | 38.92.36 | 38.23.36 |
| 38    | 38.92.38 | 38.23.38 |
| 40    | 38.92.40 | 38.23.40 |
| 42    | 38.92.42 | 38.23.42 |
| 44    | 38.92.44 | 38.23.44 |
| 46    | 38.92.46 | 38.23.46 |
| 48    | 38.92.48 | 38.23.48 |
| 50    | 38.92.50 | 38.23.50 |
| 52    | 38.92.52 | 38.23.52 |
| 54    | 38.92.54 | 38.23.54 |
| 56    | 38.92.56 | 38.23.56 |
| 58    | 38.92.58 | 38.23.58 |
| 60    | 38.92.60 | 38.23.60 |

## ANCILLAIRE

| N° | PRODUIT                                   | RÉF.     |
|----|---|----------|
| 1  | Forêt tête pour vis Ø 4.0                 | 14.37.21 |
| 2  | Tournevis (lame) canulé Mi Screw Ø 4.0    | 14.30.10 |
| 3  | Forêt pour vis Ø 4.0                      | 14.37.33 |
| 4  | Manche de tournevis AO universel          | 14.32.03 |
| 5  | Broches Ø 1.50 Lg 150 mm 1 pointe trocart | 14.63.44 |
| 6  | Tournevis (lame) canulé pour vis Ø 3.0    | 14.30.23 |
| 7  | Forêt pour vis Ø 3.0                      | 14.37.24 |
| 8  | Mesureur sur broche 150 mm                | 14.33.33 |
| 9  | Forêt tête pour vis Ø 3.0                 | 14.37.20 |
| 10 | Broches Ø 1.0 Lg 150 mm 1 pointe trocart  | 14.63.48 |
| 11 | Boîte de rangement                        | 14.10.01 |

